

JVC

SERVICE MANUAL

CD RECEIVER

KD-S680

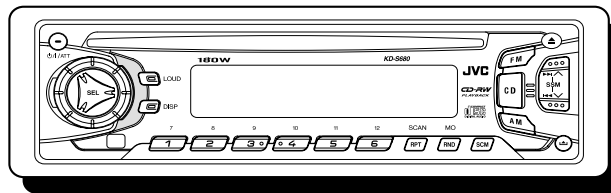
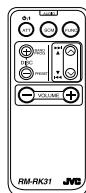
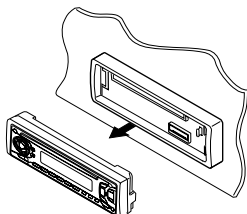

Area Suffix
 J ----- Northern America

Contents

Safety precaution	1-2	Flow of functional	
Preventing static electricity	1-3	operation unit TOC read	1-12
Disassembly method	1-4	Maintenance of laser pickup	1-14
Adjustment method	1-11	Description of major ICs	1-15

Safety precaution

 **CAUTION** Burrs formed during molding may be left over on some parts of the chassis. Therefore, pay attention to such burrs in the case of performing repair of this system.

 **CAUTION** Please use enough caution not to see the beam directly or touch it in case of an adjustment or operation check.

Preventing static electricity

1. Grounding to prevent damage by static electricity

Electrostatic discharge (ESD), which occurs when static electricity stored in the body, fabric, etc. is discharged, can destroy the laser diode in the traverse unit (optical pickup). Take care to prevent this when performing repairs.

2. About the earth processing for the destruction prevention by static electricity

Static electricity in the work area can destroy the optical pickup (laser diode) in devices such as CD players. Be careful to use proper grounding in the area where repairs are being performed.

2-1 Ground the workbench

Ground the workbench by laying conductive material (such as a conductive sheet) or an iron plate over it before placing the traverse unit (optical pickup) on it.

2-2 Ground yourself

Use an anti-static wrist strap to release any static electricity built up in your body.

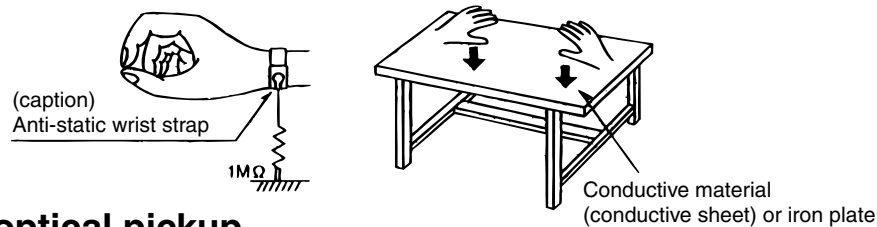

3. Handling the optical pickup

1. In order to maintain quality during transport and before installation, both sides of the laser diode on the replacement optical pickup are shorted. After replacement, return the shorted parts to their original condition. (Refer to the text.)
2. Do not use a tester to check the condition of the laser diode in the optical pickup. The tester's internal power source can easily destroy the laser diode.

4. Handling the traverse unit (optical pickup)

1. Do not subject the traverse unit (optical pickup) to strong shocks, as it is a sensitive, complex unit.
2. Cut off the shorted part of the flexible cable using nippers, etc. after replacing the optical pickup. For specific details, refer to the replacement procedure in the text. Remove the anti-static pin when replacing the traverse unit. Be careful not to take too long a time when attaching it to the connector.
3. Handle the flexible cable carefully as it may break when subjected to strong force.
4. It is not possible to adjust the semi-fixed resistor that adjusts the laser power. Do not turn it

Attention when traverse unit is decomposed

***Please refer to "Disassembly method" in the text for pick-up and how to detach the substrate.**

1. Solder is put up before the card wire is removed from connector on the CD substrate as shown in Figure.
(When the wire is removed without putting up solder, the CD pick-up assembly might destroy.)
2. Please remove solder after connecting the card wire with when you install picking up in the substrate.

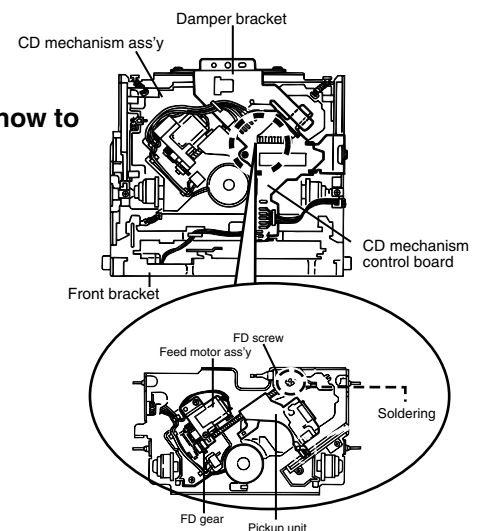

Disassembly method

<Main body>

■ Removing the front panel assembly (See Fig.1)

1. Press the eject button in the lower right part of the front panel. Remove the front panel assembly from the body.

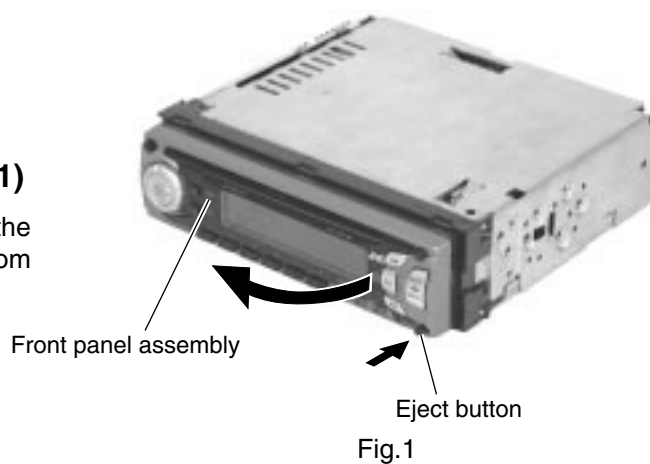

■ Removing the front chassis assembly (See Fig.2 and 3)

- Prior to performing the following procedure, remove the front panel assembly.
1. Release the four joint tabs **a** on both sides of the front chassis assembly and remove the front chassis assembly toward the front.

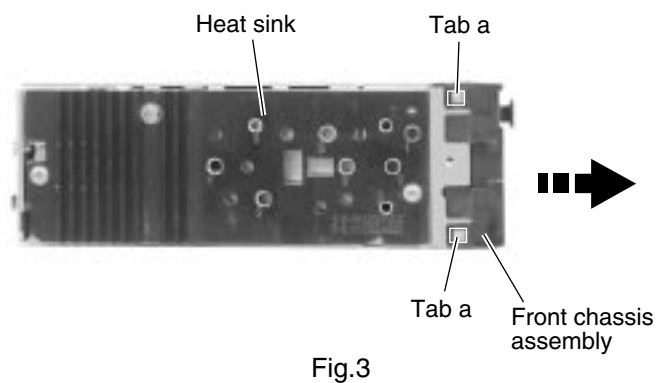
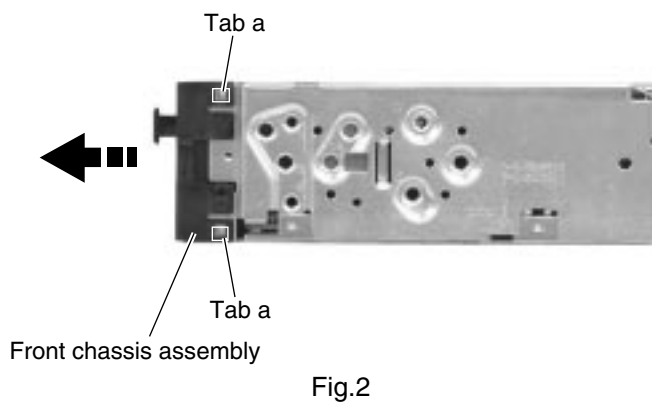

■ **Removing the heat sink (See Fig.4)**

1. Remove the three screws **A** on the left side of the body.

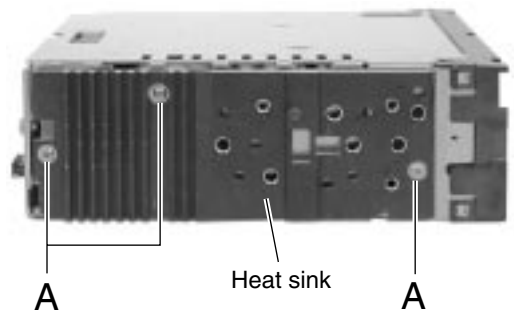

Fig.4

■ **Removing the bottom cover (See Fig.5 and 6)**

- Prior to performing the following procedure, remove the front panel assembly, the front chassis assembly and the heat sink.

1. Turn over the body and unjoint the five joints **b** with the bottom cover and the body using a screwdriver.

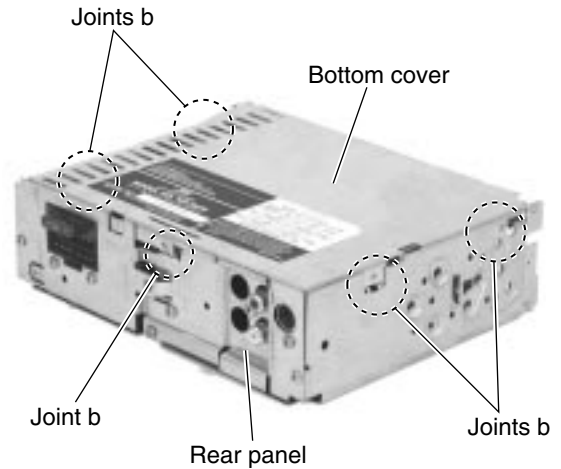

Fig.5

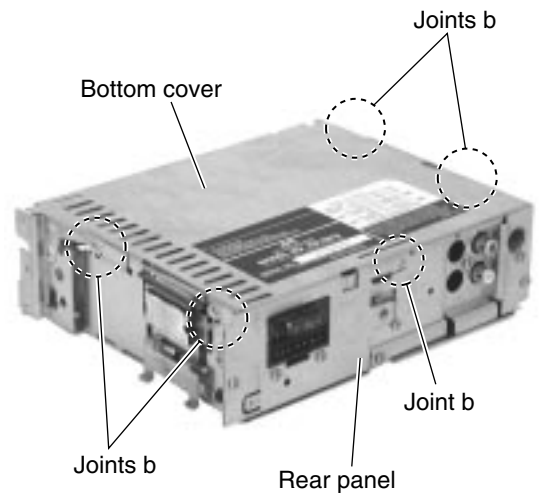

Fig.6

■ Removing the main board
(See Fig.7 and 8)

• Prior to performing the following procedure, remove the front panel assembly, the front chassis assembly, the heat sink and the bottom cover.

1. Remove the screw **B**, the four screws **C** and the three screws **D** attaching the rear panel on the back of the body. Remove the rear panel.
2. Remove the two screws **E** attaching the main board on the bottom of the body. Disconnect connector CN501 on the main board in the direction of the arrow.

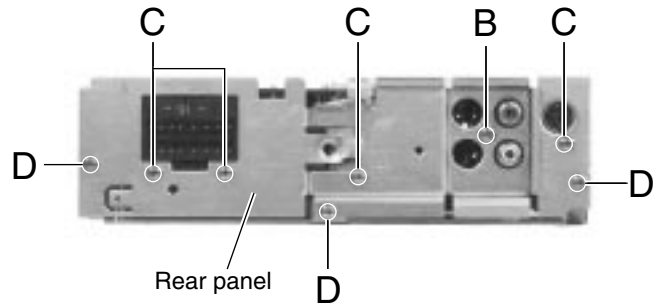

Fig.7

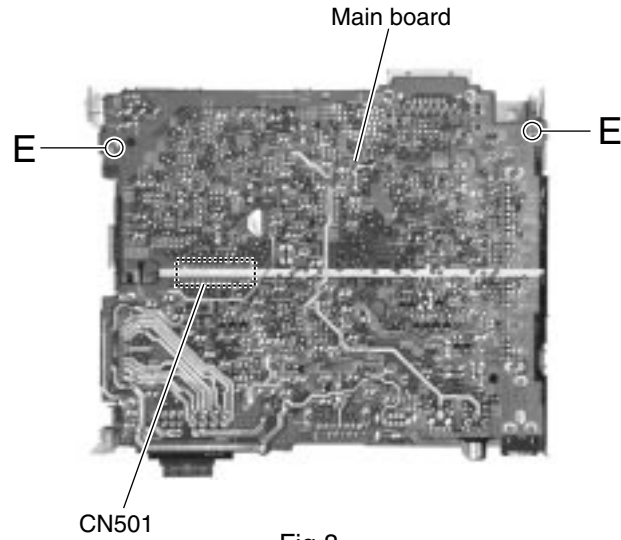

Fig.8

■ Removing the CD mechanism section
(See Fig.9)

• Prior to performing the following procedure, remove the front panel assembly, the front chassis assembly, the heat sink, the bottom cover and the main board.

1. Remove the three screws **F** attaching the cassette mechanism section on the back of the top chassis.

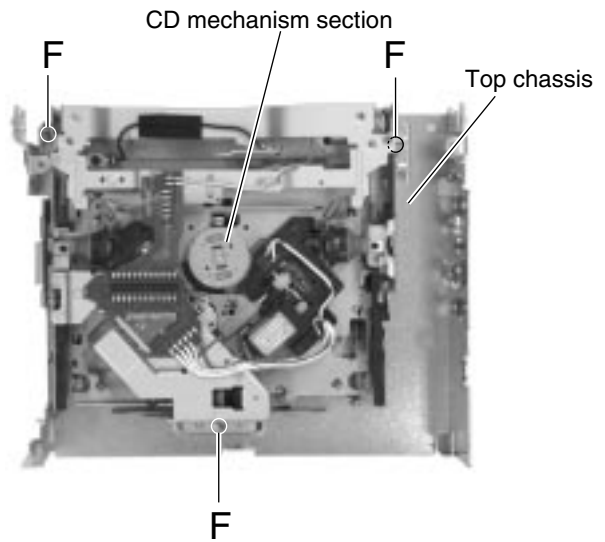

Fig.9

■ Removing the control switch board (See Fig.10 to 12)

- Prior to performing the following procedure, remove the front panel assembly.
1. Remove the four screws **G** attaching the rear cover on the back of the front panel assembly.
 2. Unjoint the ten joints **c** with the front panel and the rear cover.
 3. Remove the control switch board on the back of the front panel.

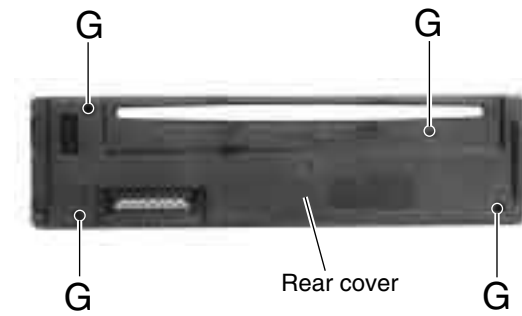

Fig.10

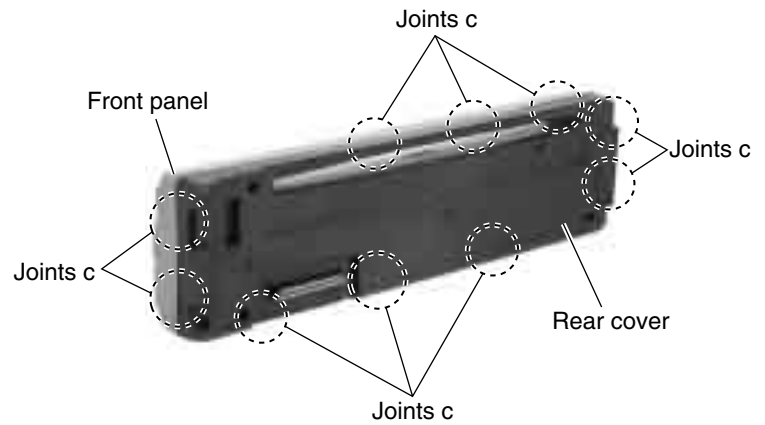

Fig.11

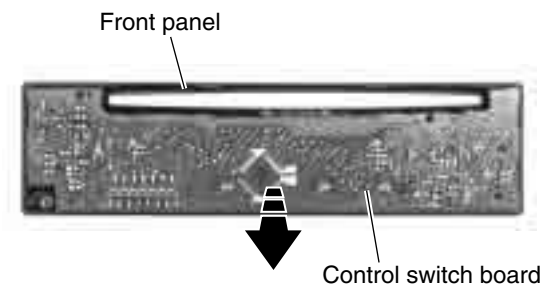

Fig.12

<CD mechanism section>

■ Removing the CD mechanism control board (See Fig.1 and 2)

1. Unsolder the part **a** and **b** on the CD mechanism control board.
2. Remove the stator fixing the CD mechanism control board and the damper bracket (To remove the stator smoothly, pick up the center part).
3. Remove the screw **A** attaching the CD mechanism control board.
4. Remove the CD mechanism control board in the direction of the arrow while releasing it from the two damper bracket slots **d** and the front bracket slot **e**.
5. Disconnect the flexible wire from connector on the pickup unit.

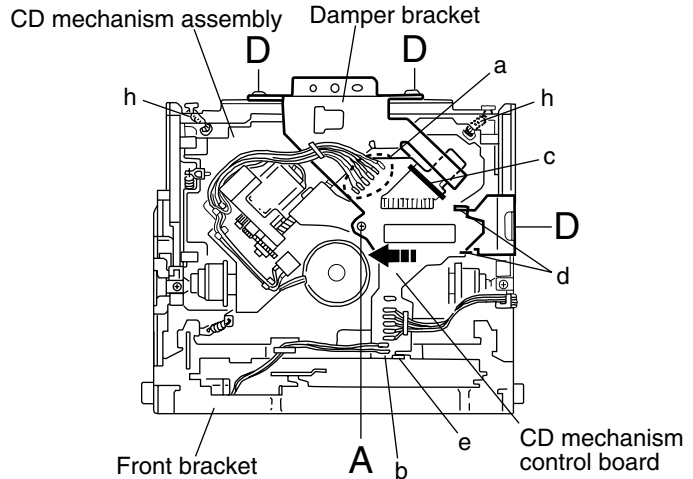

Fig.1

ATTENTION: Turn the FD gear in the direction of the arrow to move the entire pickup unit to the appropriate position where the flexible wire of the CD mechanism unit can be disconnected easily.
(Refer to Fig.2)

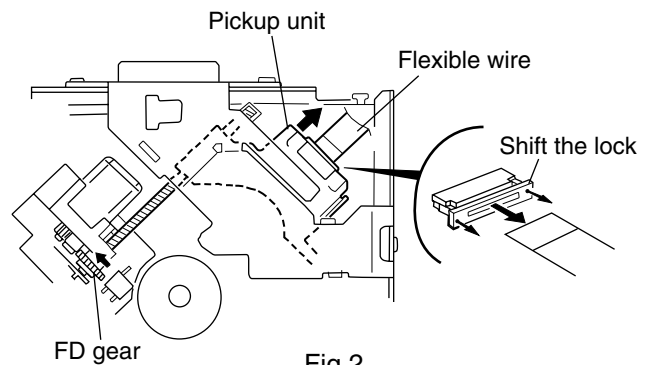

Fig.2

■ Removing the loading motor (See Fig.3 to 5)

- Prior to performing the following procedure, remove the CD mechanism control board.
1. Remove the two springs **f** attaching the CD mechanism assembly and the front bracket.
 2. Remove the two screws **B** and the front bracket while pulling the flame outward.
 3. Remove the belt and the screw **C** from the loading motor.

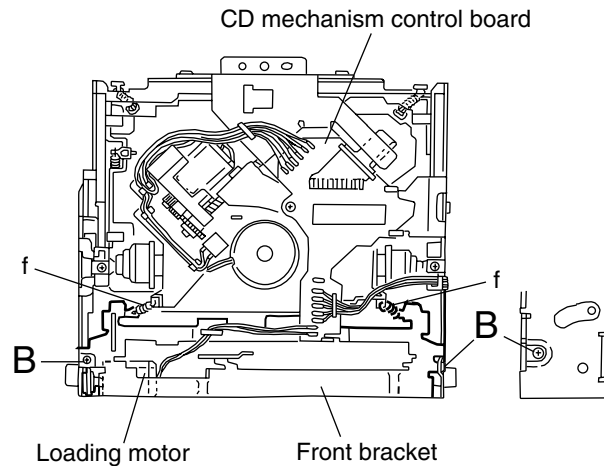

Fig.3

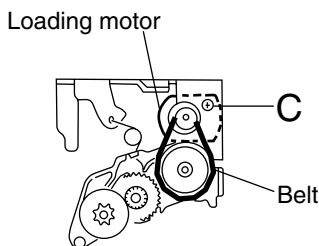

Fig.5

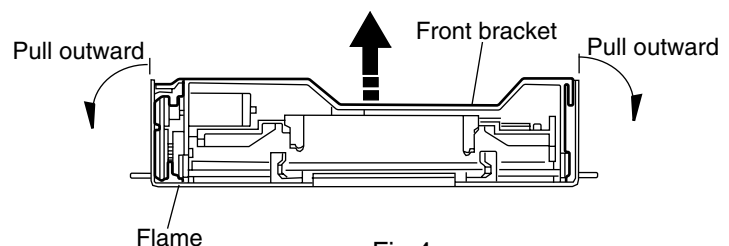

Fig.4

**■ Removing the CD mechanism assembly
(See Fig.1, 6 to 9)**

• Prior to performing the following procedure, remove the CD mechanism control board and the front bracket (loading motor).

1. Remove the three screws **D** and the damper bracket.
2. Raise the both sides fix arms and move the fix plates in the direction of the arrow to place the four shafts **g** as shown in Fig.8 and 9.
3. Remove the CD mechanism assembly and the two springs **h** attaching the flame.
4. Remove the two screws **E** and both sides rear damper brackets from the dampers. Detach the CD mechanism assembly from the left side to the right side.

ATTENTION: The CD mechanism assembly can be removed if only the rear damper bracket on the left side is removed.

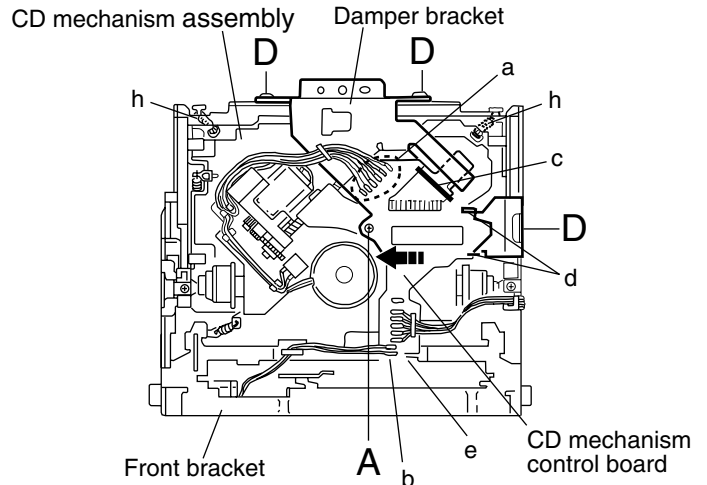

Fig.5

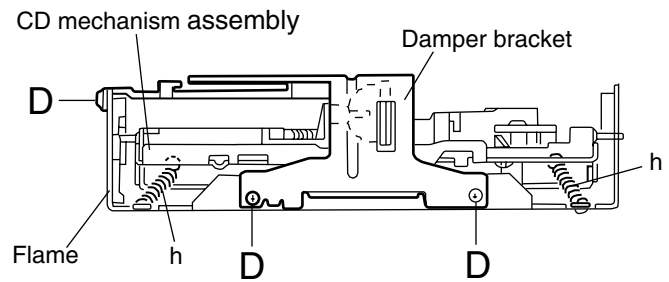

Fig.6

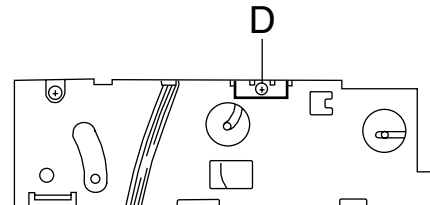

Fig.7

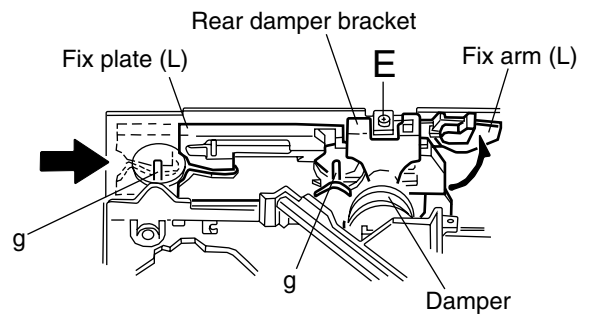

Fig.8

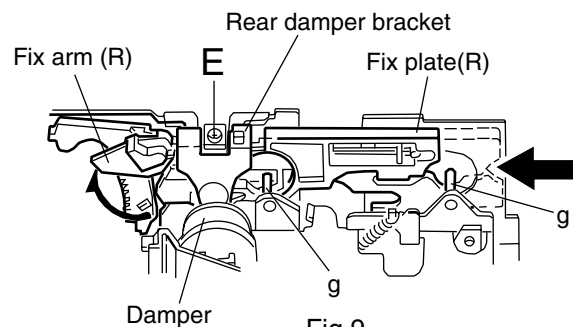

Fig.9

■ Removing the feed motor assembly
(See Fig.10)

• Prior to performing the following procedure, remove the CD mechanism control board, the front bracket (loading motor) and the CD mechanism assembly.

1. Remove the two screws **F** and the feed motor assembly.

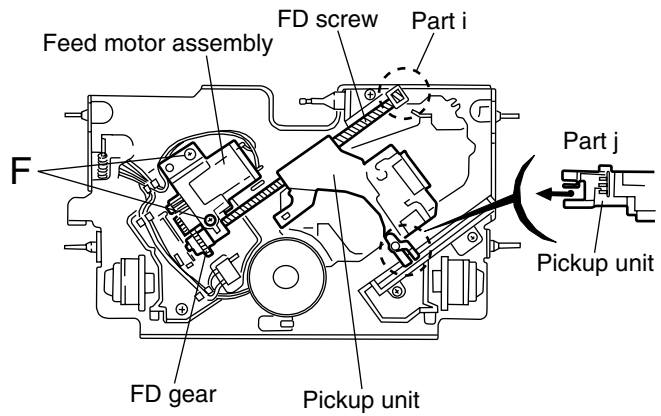

Fig.10

■ Removing the pickup unit
(See Fig.10 and 11)

• Prior to performing the following procedure, remove the CD mechanism control board, the front bracket (loading motor), the CD mechanism assembly and the feed motor assembly.

1. Detach the FD gear part of the pickup unit upward. Then remove the pickup unit while pulling out the part **i** of the FD screw.

ATTENTION: When reattaching the pickup unit, reattach the part **j** of the pickup unit, then the part **i** of the FD screw.

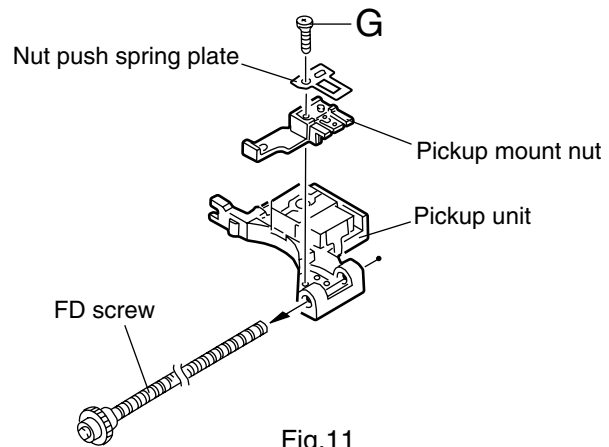

Fig.11

2. Remove the screw **G** attaching the nut push spring plate and the pickup mount nut from the pickup unit. Pull out the FD screw.

■ Removing the spindle motor
(See Fig.12 and 13)

• Prior to performing the following procedure, remove the CD mechanism control board, the front bracket (loading motor), the CD mechanism assembly and the feed motor assembly.

1. Turn up the CD mechanism assembly and remove the two springs **k** on both sides of the clamber arms. Open the clamber arm upward.
2. Turn the turn table, and remove the two screws **H** and the spindle motor.

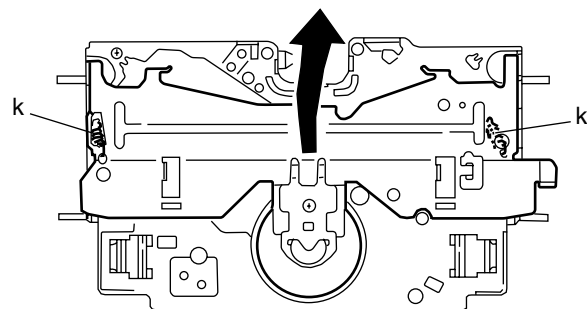

Fig.12

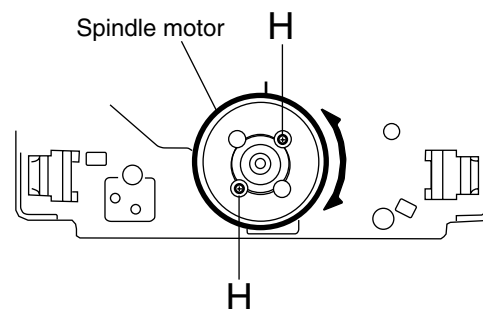

Fig.13

Adjustment method

■ Test instruments required for adjustment

1. Digital oscilloscope (100MHz)
2. AM Standard signal generator
3. FM Standard signal generator
4. Stereo modulator
5. Electric voltmeter
6. Digital tester
7. Tracking offset meter
8. Test Disc JVC :CTS-1000
9. Extension cable for check
EXTGS004-26P × 1

■ Standard volume position

Balance and Bass & Treble volume : Indication "0"
Loudness : OFF
BBE : OFF

■ Frequency Band

FM 87.5MHz ~ 107.9MHz
MW 530kHz ~ 1710 kHz

■ Dummy load

Exclusive dummy load should be used for AM, and FM. For FM dummy load, there is a loss of 6dB between SSG output and antenna input. The loss of 6dB need not be considered since direct reading of figures are applied in this working standard.

■ Standard measuring conditions

Power supply voltage DC14.4V(10.5~16V)
Load impedance 4 Ω (2 Speakers connection)
Line out impedance 20k Ω
Output Level Line out 2.0V (Vol. MAX)

■ How to connect the extension cable for adjusting

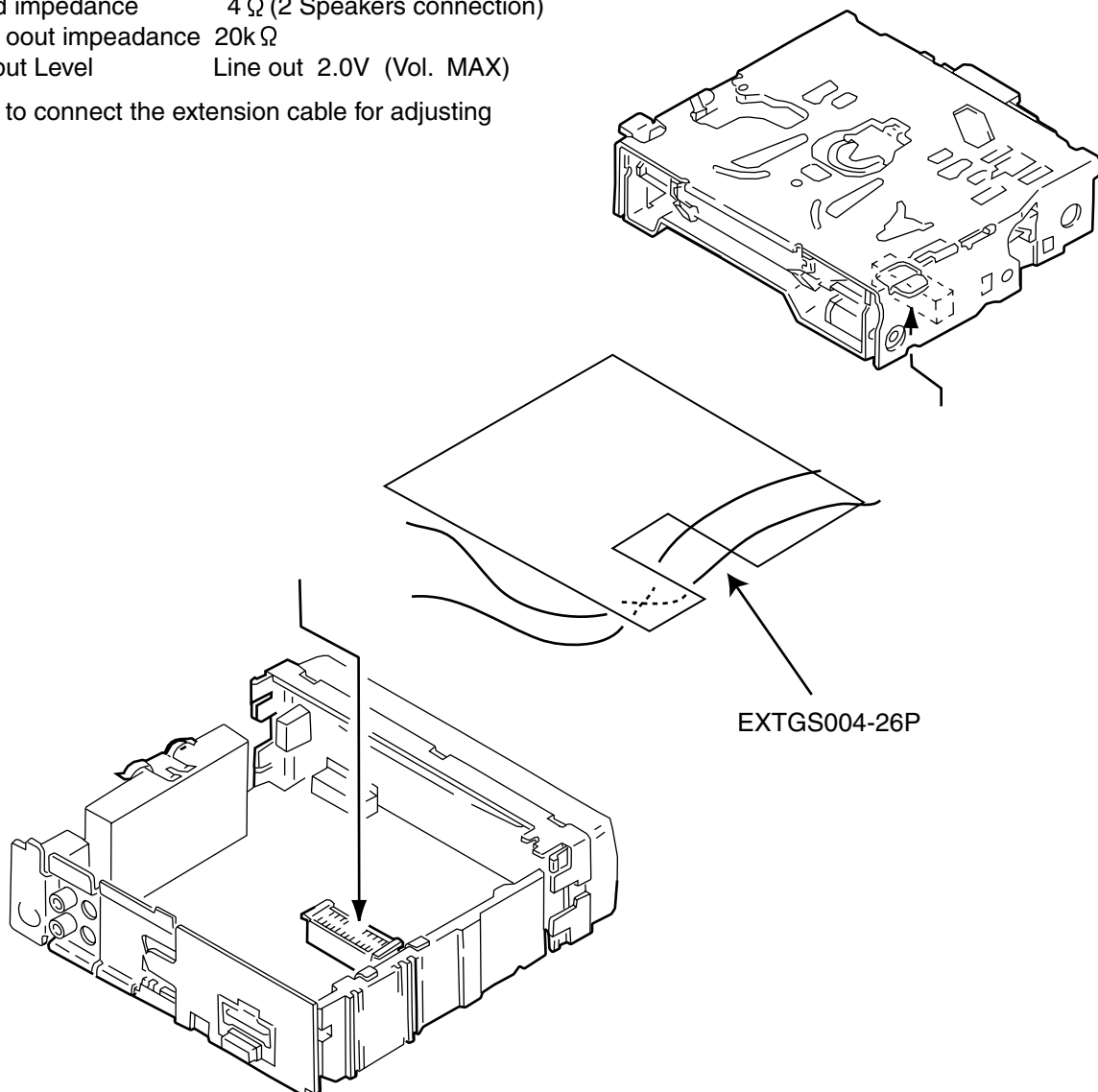

Flow of functional operation until TOC read

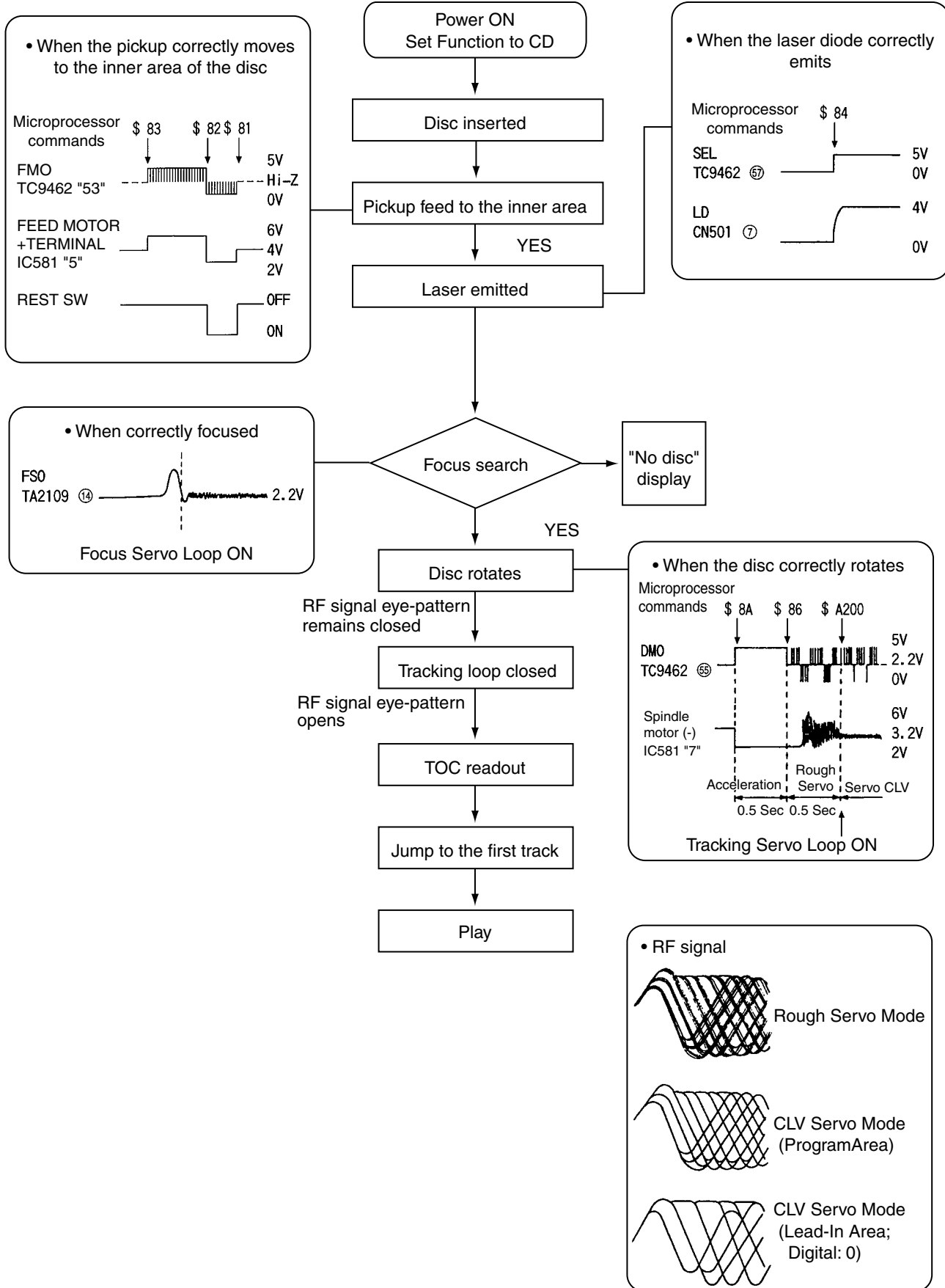

■ Feed Section

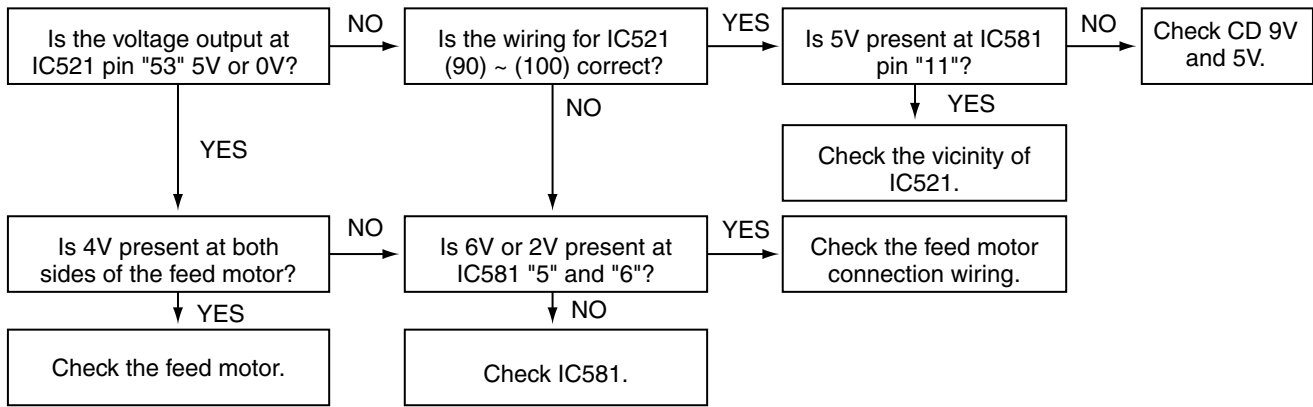

■ Focus Section

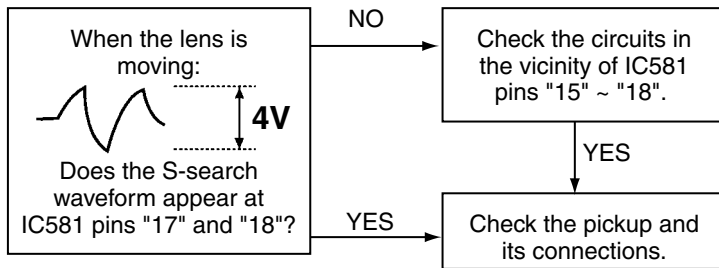

■ Spindle Section

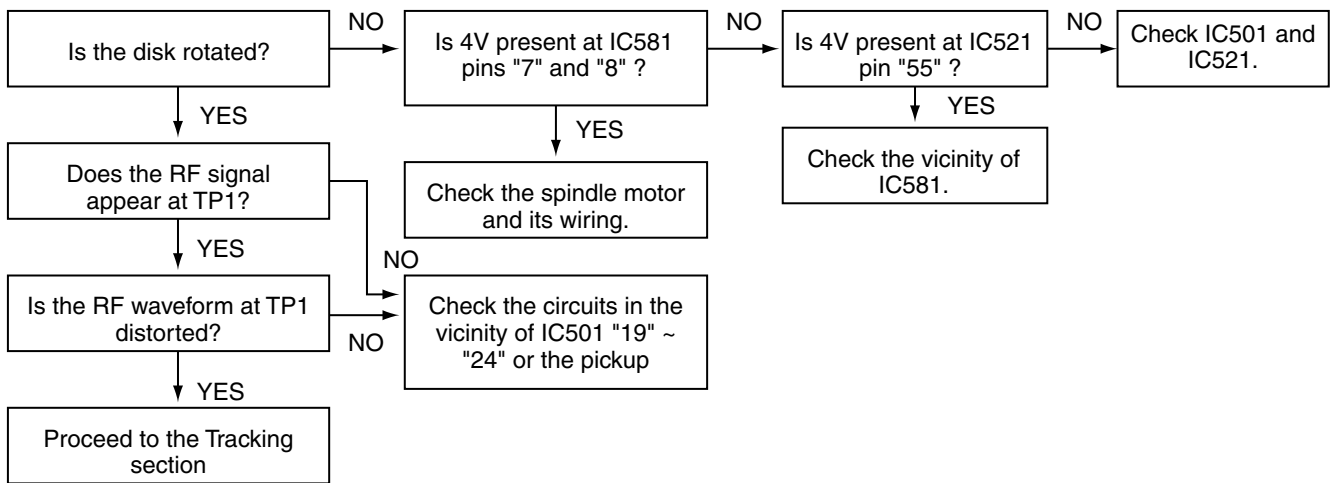

■ Tracking Section

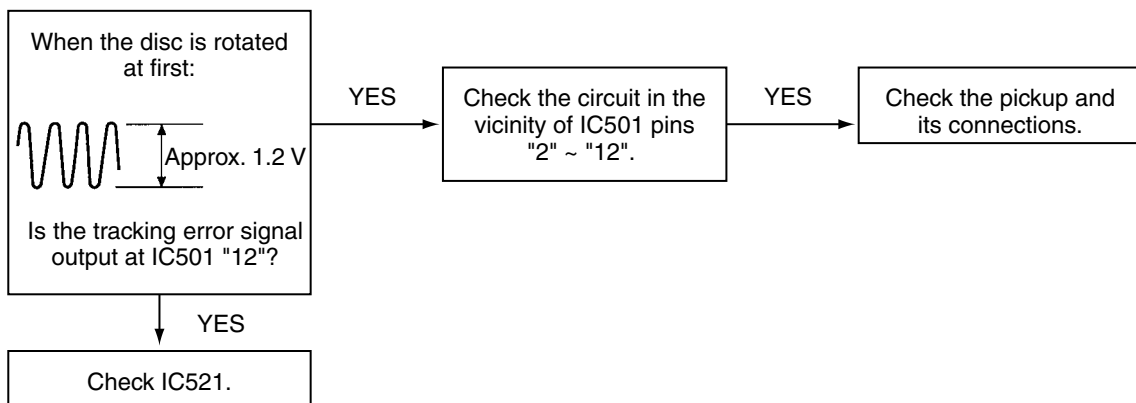

Maintenance of laser pickup

(1) Cleaning the pick up lens
 Before you replace the pick up, please try to clean the lens with a alcohol soaked cotton swab.

(2) Life of the laser diode
 When the life of the laser diode has expired, the following symptoms will appear.
 (1) The level of RF output (EFM output: amplitude of eye pattern) will be low.

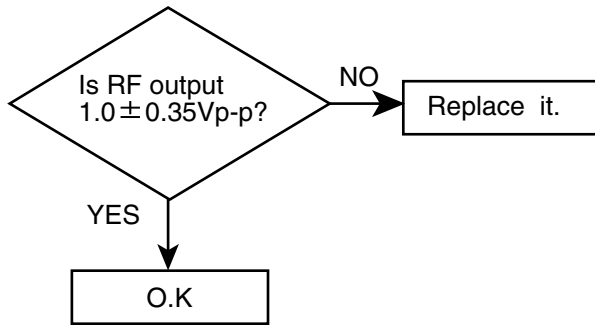

Replacement of laser pickup

(3) Semi-fixed resistor on the APC PC board
 The semi-fixed resistor on the APC printed circuit board which is attached to the pickup is used to adjust the laser power. Since this adjustment should be performed to match the characteristics of the whole optical block, do not touch the semi-fixed resistor.
 If the laser power is lower than the specified value, the laser diode is almost worn out, and the laser pickup should be replaced.
 If the semi-fixed resistor is adjusted while the pickup is functioning normally, the laser pickup may be damaged due to excessive current.

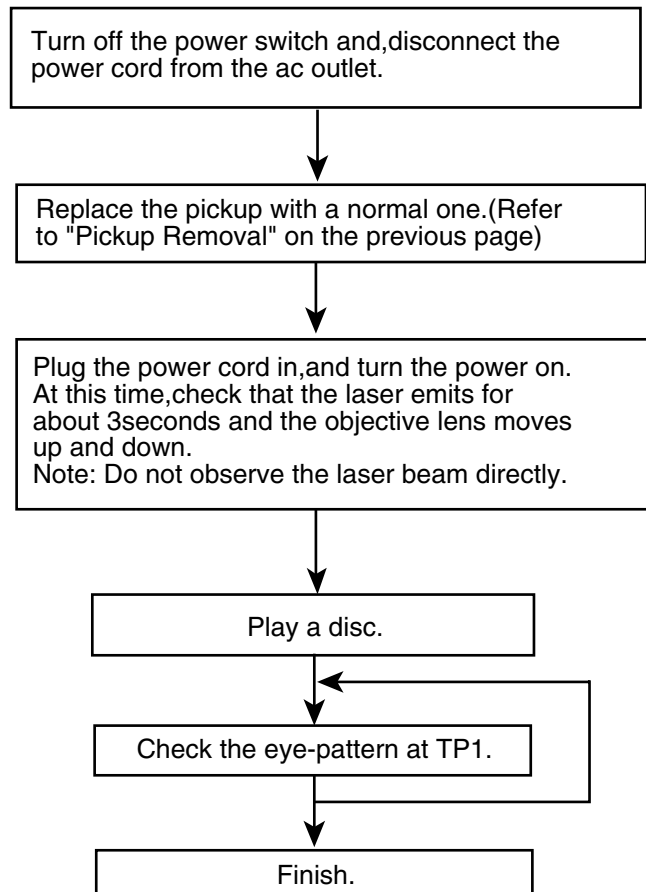

Description of major ICs

■ HA13164 (IC901) : Regulator

1. Terminal layout

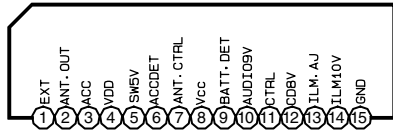

2. Block diagram

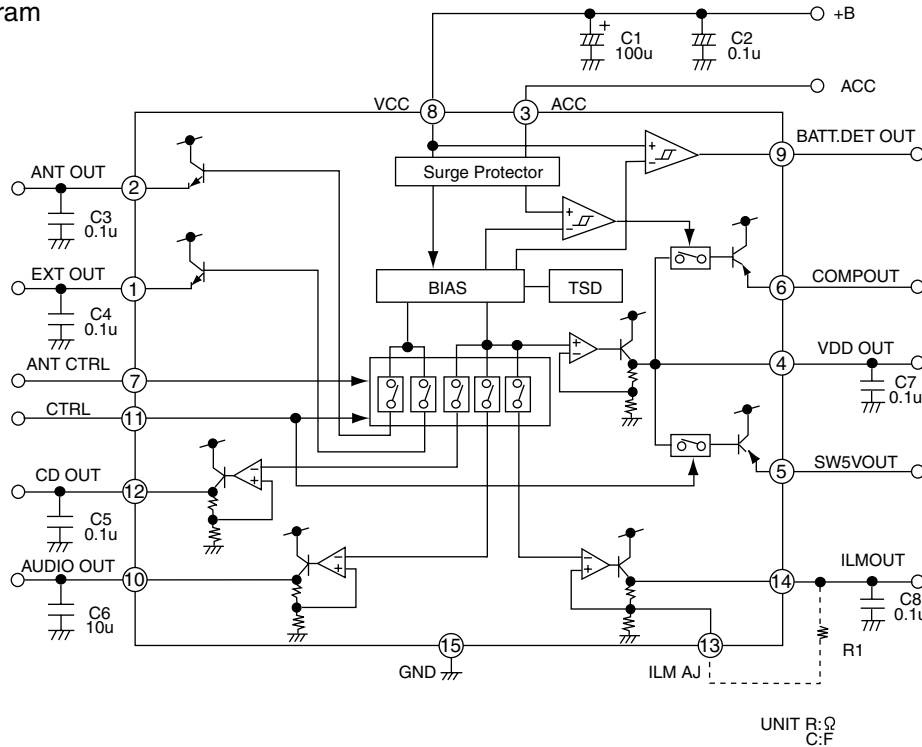

note1) TAB (header of IC)
connected to GND

3. Pin function

Pin No.	Symbol	Function
1	EXTOUT	Output voltage is VCC-1 V when M or H level applied to CTRL pin.
2	ANTOUT	Output voltage is VCC-1 V when M or H level to CTRL pin and H level to ANT-CTRL.
3	ACCIN	Connected to ACC.
4	VDDOUT	Regular 5.7V.
5	SW5VOUT	Output voltage is 5V when M or H level applies to CTRL pin.
6	COMPOUT	Output for ACC detector.
7	ANT CTRL	L:ANT output OFF , H:ANT output ON
8	VCC	Connected to VCC.
9	BATT DET	Low battery detect.
10	AUDIO OUT	Output voltage is 9V when M or H level applied to CTRL pin.
11	CTRL	L:BIAS OFF, M:BIAS ON, H:CD ON
12	CD OUT	Output voltage is 8V when H level applied to CTRL pin.
13	ILM AJ	Adjustment pin for ILM output voltage.
14	ILM OUT	Output voltage is 10V when M or H level applies to CTRL pin.
15	GND	Connected to GND.

BD3860K (IC161):E.Volume

1.Terminal layout

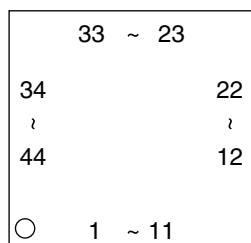

2.Blockdiagram

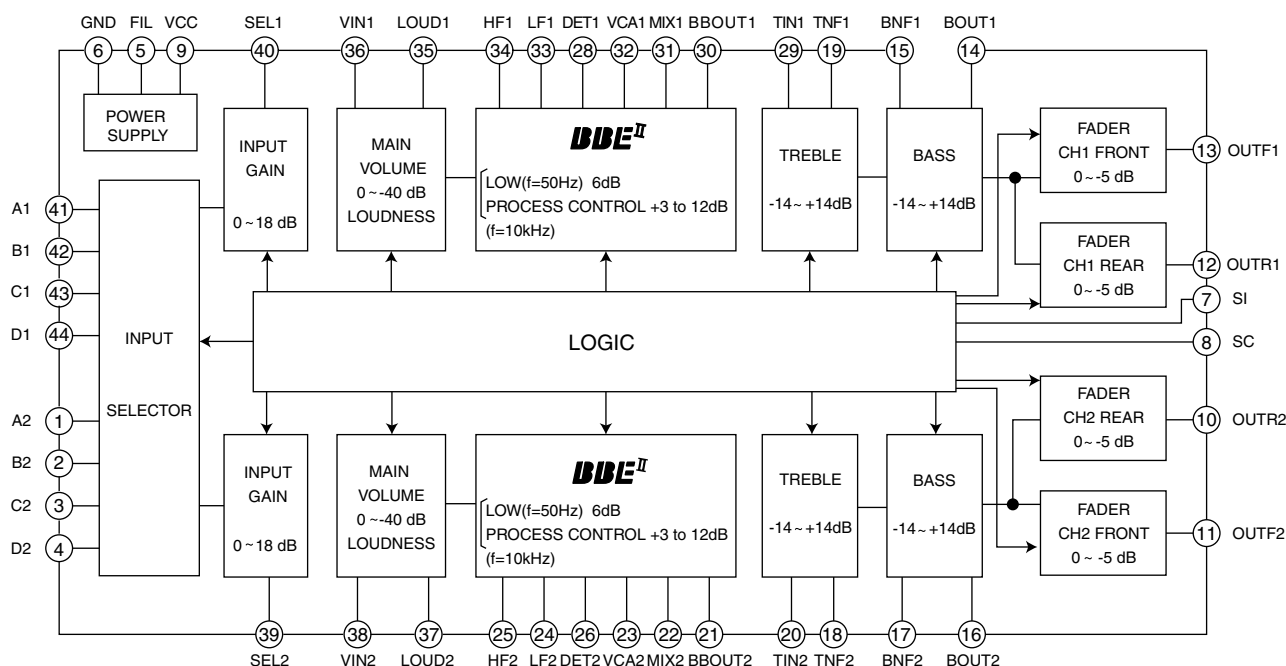

3.Pin function

Pin No.	Symbol	Function	Pin No.	Symbol	Function
1	A2	CH2 Input Pin A	23	VCA2	CH2 High Pass VCA Output Pin
2	B2	CH2 Input Pin B	24	LF2	CH2 Low Pass Filter Setting Pin
3	C2	CH2 Input Pin C	25	HF2	CH2 High Pass Filter Setting Pin
4	D2	CH2 Input Pin D	26	DET2	CH2 High Pass Attack/Release Time Setting Pin
5	FIL	1/2 VCC Pin	27	NC	Non connect
6	GND	Ground Pin	28	DET1	CH1 High Pass Attack/Release Time Setting Pin
7	SI	Serial Data Receiving Pin	29	TIN1	CH1 treble Input Pin
8	SC	Serial Clock Receiving Pin	30	BBOU1	CH1 BBE II Signal Output Pin
9	VCC	Power Supply Pin	31	MIX1	CH1 Output MIX Amplifier Inverse Input Pin
10	OUTR2	CH2 Rear Output Pin	32	VCA1	CH1 High Pass VCA Output Pin
11	OUTF2	CH2 Front Output Pin	33	LF1	CH1 Low Pass Filter Setting Pin
12	OUTR1	CH1 Rear Output Pin	34	HF1	CH1 High Pass Filter Setting Pin
13	OUTF1	CH1 Front Output Pin	35	LOUD1	CH1 Loudness Filter Setting Pin
14	BOUT1	CH1 Bass Filter Setting Pin	36	VIN1	CH1 Main Volume Input Pin
15	BNF1	CH1 Bass Filter Setting Pin	37	LOUD2	VCH2 Loudness Filter setting Pin
16	BOUT2	CH2 Bass Filter Setting Pin	38	VIN2	CH2 Main Volume Input Pin
17	BNF2	CH2 Bass Filter Setting Pin	39	SEL2	CH2 Input Gain Output Pin
18	TNF2	CH2 treble Filter Setting Pin	40	SEL1	CH1 Input Gain output Pin
19	TNF1	CH1 treble Filter Setting Pin	41	A1	CH1 Input Pin A
20	TIN2	CH2 treble Input Pin	42	B1	CH1 Input Pin B
21	BBOU2	CH2 BBE II Signal Output Pin	43	C1	CH1 Input Pin C
22	MIX2	CH2 Output MIX Amplifier Inverse Input Pin	44	D1	CH1 Input Pin D

■ LA6574H-X (IC561) : Power AMP

1.Pin layout / Block diagram

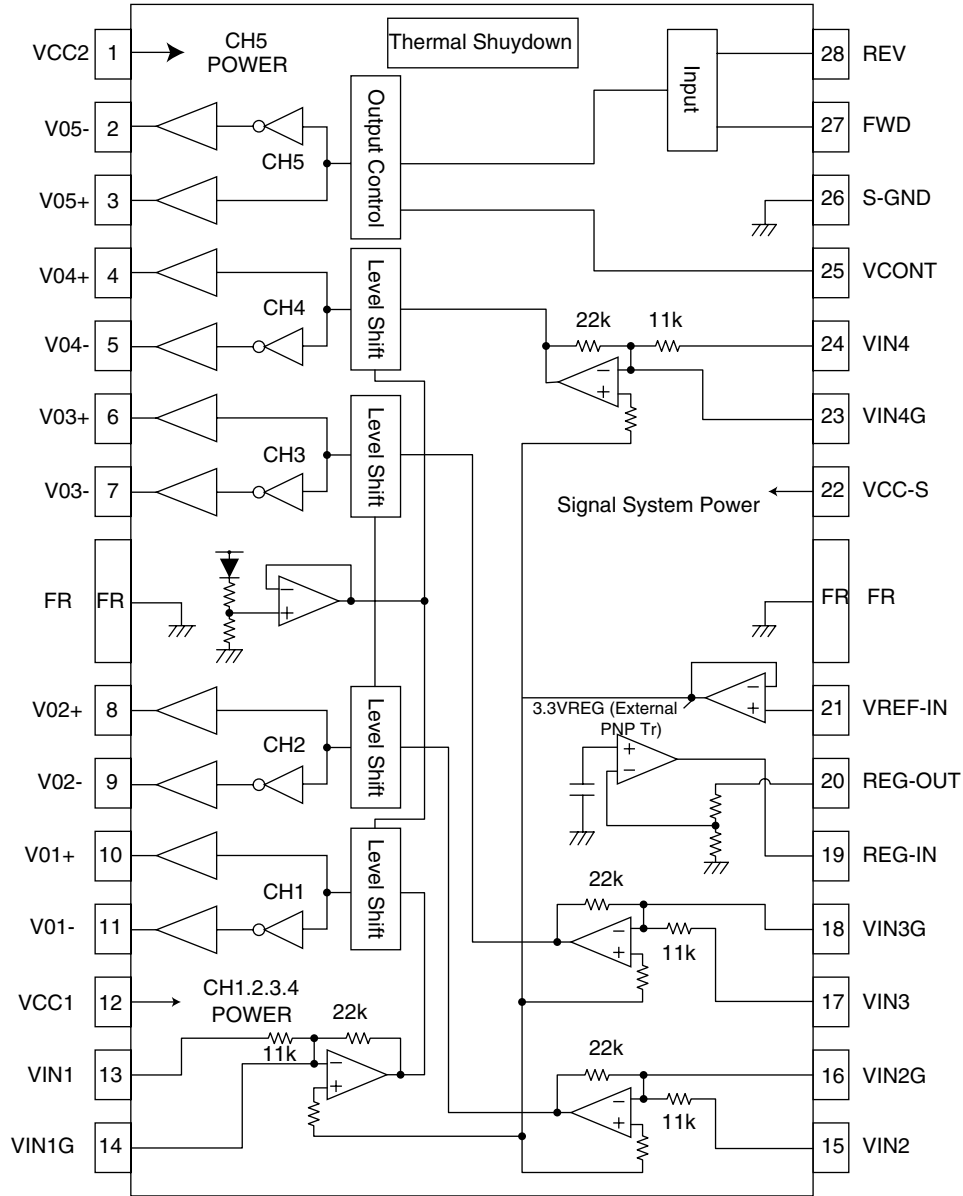

2.Pin function

PinNo.	Symbol	Function	PinNo.	Symbol	Function
1	VCC2	CH3,4,5 power supply	15	VIN2	CH2 input terminal
2	VO5-	Loading output (-)	16	VIN2G	CH2 input terminal (For gain ADJ)
3	VO5+	Loading output (+)	17	VIN3	CH3 input terminal
4	VO4+	CH4 output terminal (+)	18	VIN3G	CH3 input terminal (For gain ADJ)
5	VO4-	CH4 output terminal (-)	19	REG-IN	Regulator terminal
6	VO3+	CH3 output terminal (+)	20	REG-OUT	Regulator terminal
7	VO3-	CH3 output terminal (-)	21	VREF-IN	Reference voltage input terminal
8	VO2+	CH2 output terminal (+)	22	VCC-S	Signal system power supply
9	VO2-	CH2 output terminal (-)	23	VIN4G	CH4 input terminal (For gain ADJ)
10	VO1+	CH1 output terminal (+)	24	VIN4	CH4 input terminal
11	VO1-	CH1 output terminal (-)	25	VCONT	5CH output voltage setting terminal
12	VCC1	CH1,2 power supply	26	S-GND	GND for signal line
13	VIN1	CH1 input terminal	27	FWD	5CH output select terminal
14	VIN1G	CH1 input terminal (For gain ADJ)	28	REV	5CH output select terminal

■ UPD178078GF-559 (IC701) : System CPU

1.Pin layout

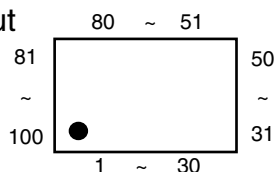

2.Pin function (1/2)

Pin NO.	Symbol	I/O	FUNCTION
1		-	No use
2	BUSINT	I	JVC bus communication line
3	BUSSI	I	JVC bus communication line
4	BUSO	O	JVC bus communication line
5	JBUS-SCK	O	JVC bus communication line
6,7,8		-	No use
9	VOL-DA	O	Serial data for volume
10	VOL-CLK	O	Serial clock for volume
11		-	No use
12	LCDDA	O	LCD driver serial data output
13	LCDCLK	O	Serial data for LCD
14	BUSI/O	O	JVC bus output select
15		-	No use
16	LCDCE	O	LCD driver communication line
17	SW2	I	CD mech switch
18	SW3	I	CD mech switch
19	SW4	I	CD mech switch
20	RSTSW	I	Traverse mech rest switch
21	ENC1	I	Encoder input
22	ENC2	I	Encoder input
23	KEY0	I	Key input
24	KEY1	I	Key input
25	KEY2	I	Key input
26	LEVEL	I	Audio level input
27	AVDD	-	Power supply
28	SM	I	Signal level meter input
29		-	No use
30,31		-	No use
32	AVSS	-	Connect to GND
33	REGCPU	-	Connect to GND with capacitor
34	VDD	-	Power supply
35	REGOSC	-	Connect to GND with capacitor
36	X2	-	System clock
37	X1	I	System clock
38	GND0	-	Connect to GND
39	SD/ST	I	Station detector & Stereo indicator
40	GND2	-	Connect to GND
41		-	No use
42	IFC	I	IF count input
43	VDDPLL	-	---
44	OSC	I	FM,AM osc input
45		-	No use

2.Pin function (2/2)

UPD178078GF-559

Pin NO.	Symbol	I/O	FUNCTION
46	GNDPLL	-	---
47	AMEO	O	PLL error output for AM
48	FMEO	O	PLL error output for FM
49	IC(VPP)	-	Setting to write for flash
50	RESET	I	System reset
51	SW1	I	CD mech switch
52	REMOCON	I	Remocon input
53	VTR-LOGIC	-	No use
54	VR-CONT	-	No use
55	POWER	O	Power control
56	CDON	O	CD power control
57	MUTE	O	Mute control
58	STAGE	-	No use
59	BUZZER	-	No use
60	JAPAN	-	No use
61~67		-	No use
68	CDRW	O	CD-RW detect signal output
69	LM0	O	CD mech driver control
70	LM1	O	CD mech driver control
71	BUCK	O	CD LSI communication line
72	CCE	O	CD LSI communication line
73	BUS0	I/O	CD LSI communication line
74	BUS1	I/O	CD LSI communication line
75	BUS2	I/O	CD LSI communication line
76	BUS3	I/O	CD LSI communication line
77	RST	O	CD LSI communication line
78	PS1	I	ACC detection input
79	PS2	I	Memory detection
80	DETACH	I	Detach detection
81		-	No use
82	GND1	-	Connect to GND
83	MONO	O	Mono by force
84	SEEK/STOP	O	Switching SEEK & STOP
85	FM/AM	O	Band switch
86		-	No use
87	ANT	O	Antena regulator control signal
88	TEL MUTE	-	No use
89~98	NC	-	Non connection
99	VDDPORT	-	Vdd
100	GNDPORT	-	Connect to GND

■ LA4743K(IC302):Power AMP

1. Block diagram

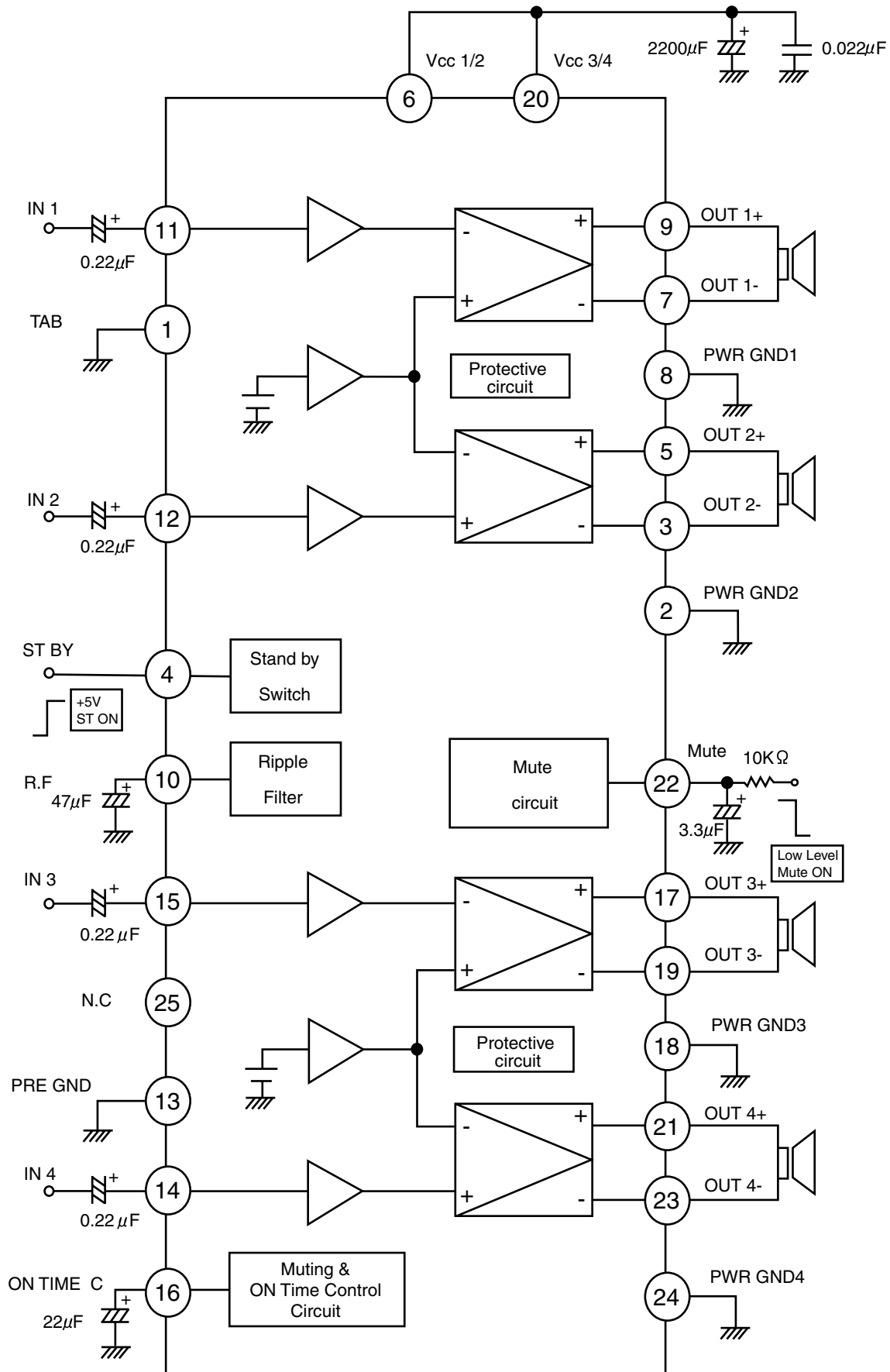

2. Terminal layout

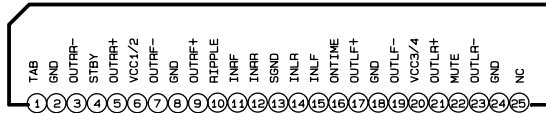

3. Pin function

LA4743K

Pin No.	Symbol	Function
1	TAB	Header of IC
2	GND	Power GND
3	OUTRR-	Outpur(-) for front Rch
4	STBY	Stand by input
5	OUTRR+	Output (+) for front Rch
6	VCC1/2	Power input
7	OUTRF-	Output (-) for rear Rch
8	GND	Power GND
9	OUTRF+	Output (+) for rear Rch
10	RIPPLE	Ripple filter
11	INRF	Rear Rch input
12	INRR	Front Rch input
13	SGND	Signal GND
14	INLR	Front Lch input
15	INLF	Rear Lch input
16	ONTIME	Power on time control
17	OUTLF+	Output (+) for rear Lch
18	GND	Power GND
19	OUTLF-	Output (-) for rear Lch
20	VCC3/4	Power input
21	OUTLR+	Output (+) for front
22	MUTE	Muting control input
23	OUTLR-	Output (-) for front
24	GND	Power GND
25	NC	Non connection

■ LC75823W (IC601) : LCD driver

1. Pin Layout & Symbol

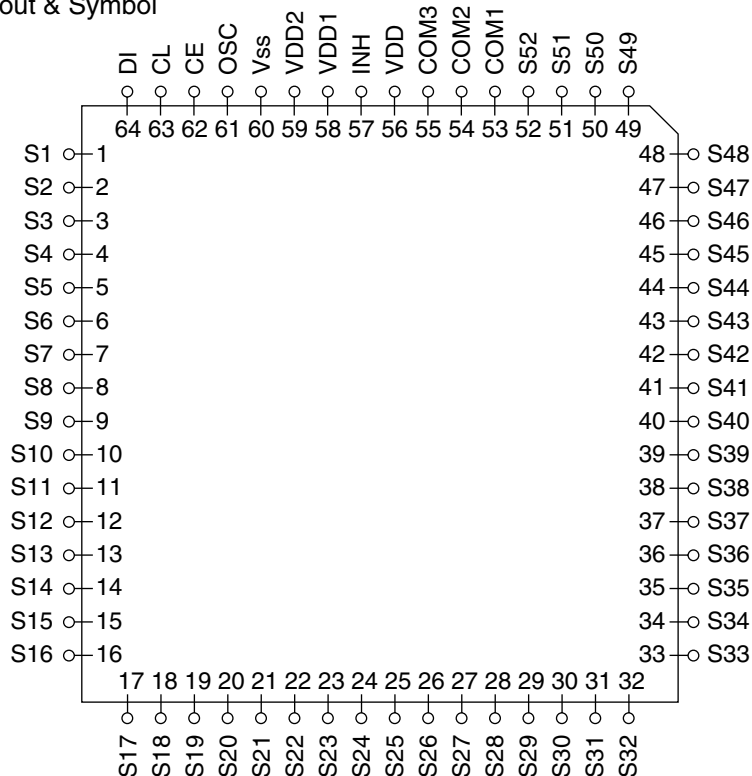

2. Pin Function

Pin No.	Symbol	I/O	Function
1 to 52	S1 to S52	O	Segment output pins used to display data transferred by serial data input.
53 to 55	COM1 to COM3	O	Common driver output pins. The frame frequency is given by : $t_0 = (f_{osc}/384)Hz$.
56	VDD	--	Power supply connection. Provide a voltage of between 4.5 and 6.0V.
57	\overline{INH}	I	Display turning off input pin. $\overline{INT} = "L"$ (Vss) ----- off (S1 to S52, COM1 to COM3="L" $\overline{INT} = "H"$ (VDD)----- on Serial data can be transferred in display off mode.
58	VDD1	I	Used for applying the LCD drive 2/3 bias voltage externally. Must be connected to VDD2 when a 1/2 bias drive scheme is used.
59	VDD2	I	Used for applying the LCD drive 1/3 bias voltage externally. Must be connected to VDD1 when a 1/2 bias drive scheme is used.
60	Vss	--	Power supply connection. Connect to GND.
61	OSC	I/O	Oscillator connection. An oscillator circuit is formed by connecting an external resistor and capacitor at this pin.
62	CE		Serial data interface connection CE : Chip enable
63	CL	I	to the controller. CL : Sync clock
64	DI		DI : Transfer data

■ TA2147F-X (IC501) : RF amp

1. Pin layout & Block diagram

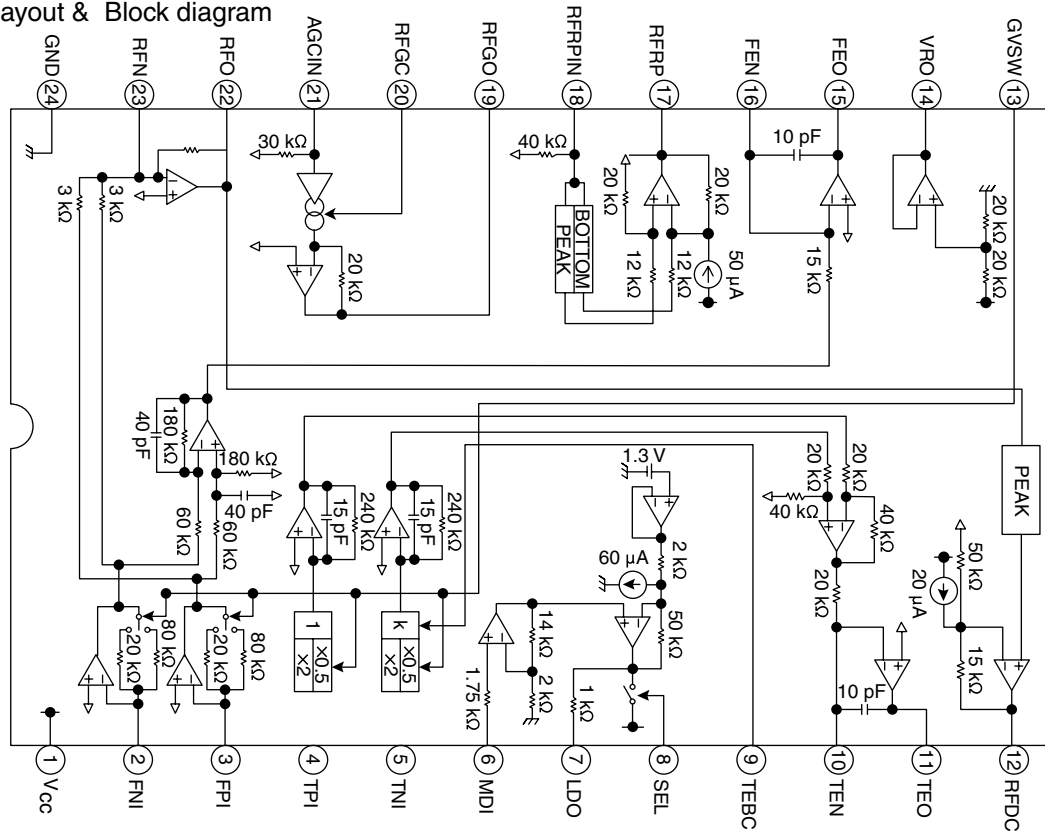

2. Pin function

Pin No.	Symbol	I/O	Function
1	Vcc	-	3.3V power supply pin
2	FNI	I	Main-beam amp input pin
3	FPI	I	Main-beam amp input pin
4	TPI	I	Sub-beam amp input pin
5	TNI	I	Sub-beam amp input pin
6	MDI	I	Monitor photo diode amp input pin
7	LDO	O	Laser diode amp output pin
8	SEL	I	APC circuit ON/OFF control signal, laser diode control signal input or bottom/peak detection frequency change pin
9	TEBC	I	Tracking error balance adjustment signal input pin
10	TEN	I	Tracking error signal generation amp negative-phase input pin
11	TEO	O	Tracking error signal generation amp output pin
12	RFDC	O	RF signal peak detection output pin
13	GVSW	I	AGC/FE/TE amp gain change pin
14	VRO	O	Reference voltage output pin
15	FEO	O	Focus error signal generation amp output pin
16	FEN	I	Focus error signal generation amp negative-phase input pin
17	RFRP	O	Signal amp output pin for track count
18	RFRPIN	I	Signal generation amp input pin for track count
19	RFGO	O	RF signal amplitude adjustment amp output pin
20	RFGC	I	RF amplitude adjustment control signal input pin
21	AGCIN	I	RF signal amplitude adjustment amp input pin
22	RFO	O	RF signal generation amp output pin
23	RFN	I	RF signal generation amp input pin
24	GND	-	GND pin

■ TC9490FA (IC521) : DSP

1. Pin layout & Block diagram

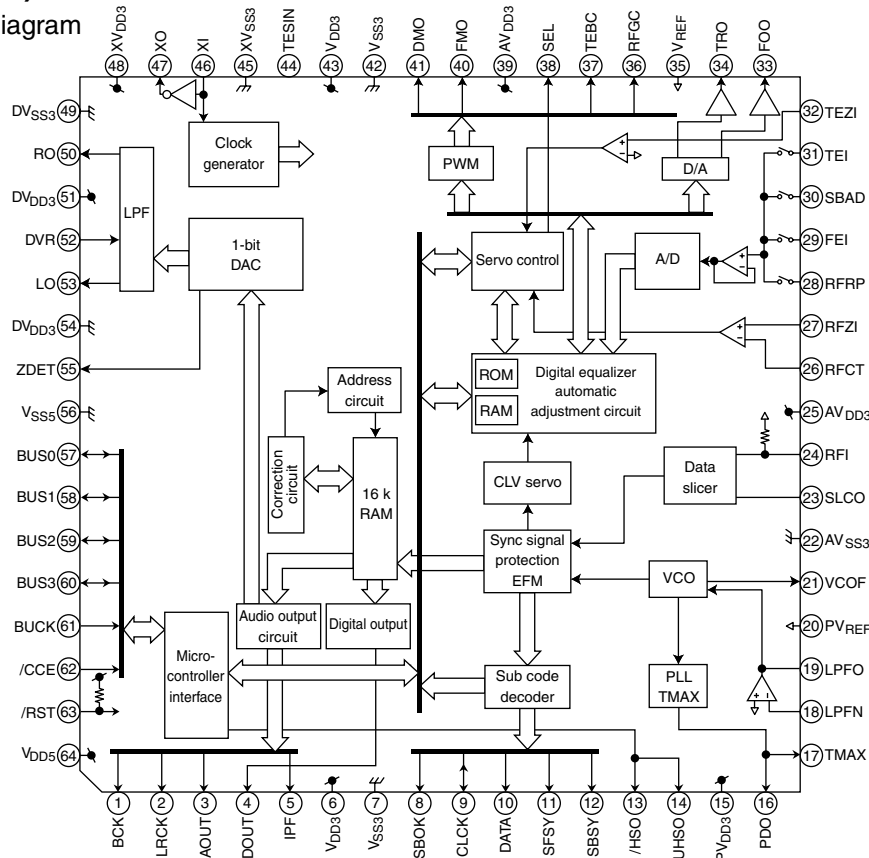

2. Pin function (1/2)

No.	Symbol	I/O	Function
1	BCK	O	Bit clock output pin.32fs, 48fs, or 64fs selectable by command.
2	LRCK	O	L/R channel clock output pin. "L" for L channel and "H" for R channel.
3	AOUT	O	Audio data output pin. MSB-first or LSB-first selected by command.
4	DOUT	O	Digital data output pin. Outputs up to double-speed playback.
5	IPF	O	Correction flog output pin.
6	VDD3	-	Digital 3.3V power supply voltage pin.
7	VSS3	-	Digital GND pin.
8	SBOK	O	Subcode Q data CRCC result output pin. "H" level when result is OK.
9	CLCK	I/O	Sub-code P-W data read clock I/O pin. I/O polarity selectable by command.
10	DATA	O	Sub-code P-W data output pin.
11	SFSY	O	Playback frames sync signal output pin.
12	SBSY	O	Sub-code block sync output pin.
13	/HSO	O	Playback speed mode flag output pin.
14	/UHSO	O	Playback speed mode flag output pin.
15	PVDD3	-	PLL-only 3.3V power supply voltage pin.
16	PDO	O	EFM and PLCK phase difference signal output pin.
17	TMAX	O	TMAX detection result output pin.
18	LPFN	I	Inverted input pin for PLL RF amp.
19	LPFO	O	Output pin for PLL LPF amp.
20	PVREF	-	PLL-only VREF pin.
21	VCOF	O	VCO filter pin.
22	AVSS3	-	Analog GND pin.
23	SLCO	O	DAC output pin for data slice level generation.
24	RFI	I	RF signal input pin.
25	AVSS3	-	Analog 3.3V power supply voltage pin.

2. Pin function (2/2)

TC9490FA

No.	Symbol	I/O	Function
26	RFCT	I	RFRP signal center level input pin.
27	RFZI	I	RFRP signal zero-cross input pin.
28	RFRP	I	RF ripple signal input pin.
29	FEI	I	Focus error signal input pin.
30	SBADTEI	I	Sub-beam adder signal input pin.
31	TEI	I	Tracking error input pin. Inputs when tracking servo is on.
32	TEZI	I	Tracking error signal zero-cross input pin.
33	FOO	O	Focus equalizer output pin.
34	TRO	O	Tracking equalizer output pin.
35	VREF	-	Analog reference power supply voltage pin.
36	RFGC	O	RF amplitude adjustment control signal output pin.
37	TEBC	O	Tracking barance control signal output pin.
38	SEL	O	APC circuit ON/OFF signal output pin.
39	AVDD3	-	Analog 3.3V power supply voltage pin.
40	FMO	O	Feed equalizer output pin.
41	DMO	O	Disc equalizer output pin.
42	VSS3	-	Digital GND pin.
43	VDD3	-	Digital 3.3V power supply voltage pin.
44	TESIN	I	Test input pin.
45	XVSS3	-	System clock oscillator GND pin.
46	XI	I	System clock oscillator input pin.
47	XO	O	System clock oscillator output pin.
48	XVDD3	-	System clock oscillator 3.3V power supply voltage pin.
49	DVSS3	-	DA converter GND pin.
50	RO	O	R-channel data foward output pin.
51	DVDD3	-	DA converter 3.3V power supply pin.
52	DVR	-	Reference voltage pin.
53	LO	O	L-channel data forward output pin.
54	DVSS3	-	DC converter GND pin.
55	ZDET	O	1 bit DA converter zero data detection flag output pin.
56	VSS5	-	Microcontroller interface GND pin.
57	BUS0	I/O	Microcontroller interface data I/O pins.
58	BUS1	I/O	Microcontroller interface data I/O pins.
59	BUS2	I/O	Microcontroller interface data I/O pins.
60	BUS3	I/O	Microcontroller interface data I/O pins.
61	BUCK	I	Microcontroller interface clock input pin.
62	/CCE	I	Microcontroller interface chip enable signal input pin.
63	/RST	I	Reset signal input pin.
64	VDD5	-	Microcontroller interface 5V power supply pin.

■ NJM4565M-WE (IC571) : Ope. amp

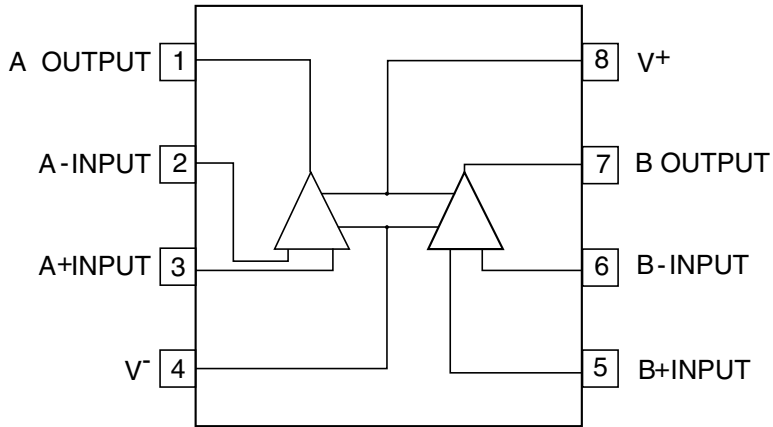

■ RPM6938-SV4(IC602) : Remote sensor

1. Block diagram

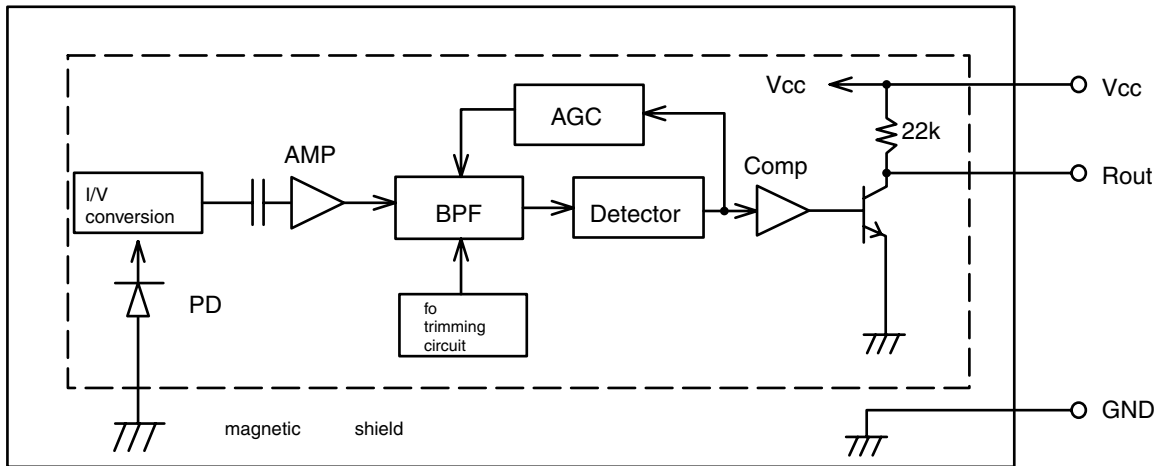



VICTOR COMPANY OF JAPAN, LIMITED

MOBILE ELECTRONICS DIVISION

PERSONAL & MOBILE NETWORK BUSINESS UNIT. 10-1,1Chome,Ohwatari-machi,Maebashi-city,371-8543,Japan